

JENSEN®

audio

JTA-220

AM / FM STEREO TURNTABLE

INSTRUCTION MANUAL



Please read and follow this instruction manual carefully before using the unit and retain it for future reference

WARNING

TO PREVENT FIRE OR SHOCK HAZARD, DO NOT USE THIS PLUG WITH AN EXTENSION CORD, RECEPTACLE OR OTHER OUTLET UNLESS THE BLADES CAN BE FULLY INSERTED TO PREVENT BLADE EXPOSURE. TO PREVENT FIRE OR SHOCK HAZARD, DO NOT EXPOSE THIS APPLIANCE TO RAIN OR MOISTURE.



The lightning flash with arrowhead symbol, within an equilateral triangle is intended to alert the user to the presence of uninsulated dangerous voltage within the products enclosure that may be of sufficient magnitude to constitute a risk of electric shock to persons.

CAUTION

**RISK OF ELECTRIC SHOCK
DO NOT OPEN**

WARNING: TO REDUCE THE RISK OF ELECTRIC SHOCK DO NOT REMOVE COVER (OR BACK), NO USER SERVICEABLE PARTS INSIDE REFER SERVICING TO QUALIFIED SERVICE PERSONNEL.



The exclamation point within an equilateral triangle is intended to alert the user to the presence of important operating and maintenance (servicing) instructions in the literature accompanying the appliance.

IMPORTANT SAFETY INSTRUCTIONS

1. Read these instructions.
2. Keep these instructions
3. Heed all warnings.
4. Follow all instructions
5. Do not use this apparatus near water
6. Cleaning-Unplug this product from the wall outlet before cleaning, Do not use liquid cleaners or aerosol cleaners. Use a dry cloth for cleaning
7. Do not block any ventilation openings. Install in accordance with the manufacturer's instructions.
8. Do not place this product on an unstable cart, stand, tripod, bracket, or table. The product may fall, causing serious injury to a child or adult, and serious damage to the product. Use only with a cart, stand, tripod, bracket, or table recommended by the manufacturer, or sold with the product. Any mounting of the product should follow the manufacturer's instructions, and should use a mounting accessory recommended by the manufacturer. A Product and Cart Combination Should Be Moved with Care-Quick stops, excessive force and uneven surfaces may cause the product and cart combination to overturn.
9. Do not install near any heat sources such as radiators, heat registers, stoves, or other apparatus (Including amplifiers) that produce heat.
10. Do not defeat the safety purpose of the polarized or grounding-type plug. A polarized or grounding-type plug has two blades with one wider than the other. A grounding type plug has two blades and a third grounding prong. The wide blade or the third prong is provided for your safety. If the provided plug does not fit into your outlet, consult an electrician for replacement of the obsolete outlet.
11. Protect the power cord from being walked on or pinched particularly at plugs convenience receptacles, and the point where they exit from the apparatus.
12. Only use attachments/accessories specified by the manufacturer.
13. Unplug this apparatus during lightening storms or when unused for long periods of time.
14. Refer all servicing to qualified service personnel. Servicing is required when the apparatus has been damaged in any way, such as power-supply cord or plug is damaged, liquid has been spilled or objects have fallen into the apparatus, the apparatus has been exposed to rain or moisture, does not operate normally, or has been dropped.
15. This appliance shall not be exposed to dripping or splashing water and that no object filled with liquids such as vases shall be placed on the apparatus.
16. Do not overload wall outlet. Use only power source as indicated.
17. Use replacement part as specified by the manufacturer.
18. The product may be mounted to a wall only if recommended by the manufacturer.
19. Upon completion of any service or repairs to this product, ask the service technician to perform safety checks.



FCC INFORMATION

This equipment has been tested and found to comply with the limits for a class B digital device, pursuant to Part 15 of the FCC Rules. These limits are designed to provide reasonable protection against harmful interference in a residential installation. This equipment generates, uses, and can radiate radio frequency energy and, if not installed and used in accordance with the instructions, may cause harmful interference to radio communications. However, there is no guarantee that interference will not occur in particular installation. If this equipment does cause harmful interference to radio or television reception, which can be determined by turning the equipment off and on, the user is encouraged to try to correct the interference by one or more of the following measures :

- Reorient or relocate the receiving antenna.
- Increase the separation between the equipment and receiver.
- Connect the equipment into an outlet on a circuit different from that to which the receiver is connected.
- Consult the dealer or an experienced radio/TV technician for help.

WARNING

Changes or modifications to this unit not expressly approved by the party responsible for compliance could void the user's authority to operate the equipment.

IMPORTANT NOTES

- Avoid installing this unit in places exposed to direct sunlight or close to heat radiating appliance such as electric heaters, on top of other stereo equipment that radiates too much heat, places lacking ventilation or dusty areas, places subject to constant vibration and / or humid or moist areas.
- Do not attempt to clean this unit with chemical solvents as this might damage the finish. Use a clean dry cloth.
- Operate controls and switches as described in the manual.
- Before turning on the power, make certain that the power cord is properly installed.
- When moving the set, be sure to first disconnect the AC power cord.

POWER SOURCE

CAUTION:
TO PREVENT ELECTRIC SHOCK, MATCH WIDE BLADE OF PLUG TO WIDE SLOT,
AND INSERT FULLY.

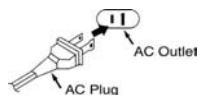

ATTENTION:

This unit is designed to operate only on normal 120V 60Hz AC house current. Operating this unit from any other power source may cause damage to unit and such damage is not covered by your warranty. This unit has a polarized AC plug with one wide blade and one narrow blade. This plug will only fit into a matching polarized AC outlet. This is a safety feature to reduce the possibility of electric shock. If this plug will not fit in your AC outlet, you probably have an out dated non-polarized outlet. You should have your outdated outlet changed by a qualified licensed electrician. Do not file the wide blade on the plug, or use an adapter to make the plug fit into your outlet. This defeats the safety feature and could expose you to electric shock.

LOCATION OF CONTROLS

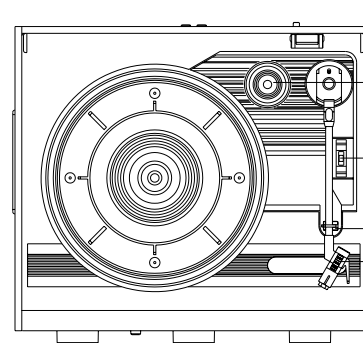

- 1) VOLUME CONTROL
- 2) HEADPHONE JACK
- 3) POWER BUTTON
- 4) POWER INDICATOR
- 5) FUNCTION SELECTOR
- 6) FM STEREO INDICATOR
- 7) TUNING KNOB
- 8) FM ANTENNA
- 9) EXTERNAL SPEAKER TERMINALS
- 10) AC POWER CORD
- 11) INTERNAL SPEAKER SHUT-OFF SWITCH
- 12) TONE ARM
- 13) TONE ARM REST
- 14) SPEED SELECTOR
- 15) 45 RPM ADAPTOR

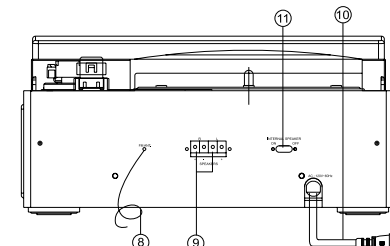
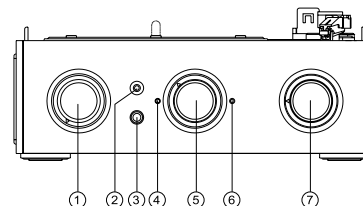

CONNECTIONS

POWER CONNECTION

Only connect the power cord to a 120VAC/60Hz household plug.

SPEAKER TERMINAL

Connect EXTERNAL SPEAKERS (NOT INCLUDED) to the SPEAKER TERMINALS(9) located on the rear of the unit (RED WIRE TO RED TERMINAL, BLACK WIRE TO BLACK TERMINAL).

This unit should not be connected to speakers with an impedance of less than 8 ohms, otherwise damage may result to the unit.

REMARK: Make sure that the INTERNAL SPEAKER Switch (11) is in "ON" position if external speakers are not connected.

HEADPHONE JACK (PHONES)

This unit will accept stereo headphones (not included) with a 1/8" plug and an impedance of 32 ohms or greater. The speakers are automatically disconnected when headphones are connected to the PHONES jack.

GENERAL

POWER BUTTON(3) – Press to turn unit on or off. The Power Indicator (4) will light when the unit is on.

VOLUME CONTROL(1) – Adjusts the volume level of the speakers or headphones.

FUNCTION SELECTOR(5) – Use to select the desired signal source (AM/FM/FM.ST or PHONO) to be listened to.

TUNER OPERATION

- 1) Turn on the unit by pressing the POWER BUTTON (3), the Power Indicator lights.
- 2) Select the desired band (AM/FM/FM St.) with the FUNCTION Control (5).
- 3) Tune in your desired station using the TUNING Knob (7). If the FM ST. band was chosen, the FM STEREO indicator (6) will light up whenever a stereo broadcast is received. To receive a weak (noisy) FM station, select FM band by setting the FUNCTION knob(5) to the FM position. The FM STEREO indicator (6) will go off and the reception may be improved, but the sound is now monaural (MONO).
- 4) Adjust the VOLUME Control (1) to the desired sound level.
- 5) To turn the unit off, press the POWER Knob (3) again, The Power Indicator (4) goes off.

HINTS FOR BEST RECEPTION

FM: The receiver has a built-in FM antenna (8) hanging from the rear cabinet. This wire should be completely unraveled and extended for best reception.

AM : This unit is equipped with a built-in directional ferrite antenna. Rotate the unit to obtain the best reception.

PHONO OPERATION

Note:

Flip-up the clear stylus protector to expose the needle. Be sure that the tone arm is detached from the tone arm rest (13) before operating.

- 1) Turn on the unit with the POWER Button (3). The POWER Indicator (4) will light up.
- 2) Set the FUNCTION Selector (5) to the PHONO position.
- 3) Set the SPEED SELECTOR (14) to the proper position depending on the record to be played. Three speeds (33 rpm, 45 rpm, 78 rpm) can be selected. When 45 rpm is selected, use the 45 rpm ADAPTOR (15).
- 4) Place the record on the platter (if required, use the 45 rpm adaptor)
- 5) Lift the tone arm (12) from the rest (13) and the platter will begin to rotate as you move it towards the record.
- 6) Place the needle of the tone arm (12) on the record at the desired position.
- 7) Adjust the VOLUME control (1) to the desired sound level.
- 8) At the end of the record, the platter will continue to rotate until the tone arm (12) is returned to the rest (13).

Note:

The turntable platter will not automatically stop when the record finishes playing. This is to allow extended play records to play all the way through without prematurely stopping before the tone arm reaches the end of the record (center area). Don't allow the record to continue turning for extended periods of time once the tone arm (12) reaches the center of the record. This could prematurely wear out the stylus needle.

- 9) Stop the Turntable by pressing the POWER Button (3). Lift the tone arm (12) and return it to the rest (13).

IMPORTANT:

Do not turn or stop the Turntable platter manually. Moving or jarring the Turntable platter without securing the Tone Arm Clamp could result in damage to the Tone Arm or Stylus.

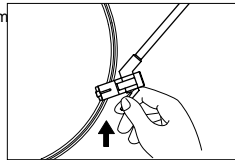

CARE & MAINTENANCE

- Do not plug in the power cord until all other connections have been made.
- Do not expose this product to liquid.

Power Button

After using the unit, switch off the power by releasing the POWER Button.

Cleaning the Unit

To clean, simply wipe with soft clean damp (never wet) cloth. Never use solvents or abrasive cleaners.

Stylus (needle) Replacement

Replace a worn stylus by following the directions below

- 1) Raise the "Tone Arm".
- 2) To remove the old stylus needle, pull out the stylus assembly in the direction shown, holding the head shell with your other hand.
- 3) Then install the new stylus needle by pushing it gently into the cartridge (hold by the edge to prevent damage to the stylus) until it clicks into place.

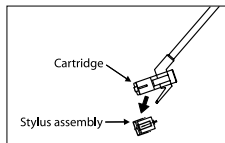

TROUBLE SHOOTING

Power button on (pushed in), but no power

- * Check power to wall plug.
- * Check AC cord connection to wall plug.

Power Indicator is on, but no sound from speaker

- * Check FUNCTION selector.
- * Check VOLUME setting
- * Make sure headphones are not plugged in.

Poor FM reception

- * Untie and fully extend the FM wire antenna for best reception.

SPECIFICATIONS

Power Supply: AC 120V ~ 60Hz

Radio Frequency Coverage: AM: 535 - 1705 KHz
FM: 88 - 108 MHz

Specifications subject to change without notice.

SERVICE

Please refer to the instructions on the enclosed warranty card for returning your unit for service.

Distributed by:

Chicago Industry Tech Park
Spectra Merchandising International, Inc.
4230 North Normandy Avenue
Chicago, IL60634, U.S.A.

Please have model number ready, for Customer Service, call 1-800-777-5331

Printed in China